

CDS

Stainless Steel Basic Pump Self Priming Centrifugal Pump

Model T6A65S-B

Size 6" x 6"

Super
TSERIES

VARIOUS PATENTS APPLY



PUMP SPECIFICATIONS

Size: 6" x 6" (152 mm x 152 mm) NPT - Female.

Casing: Stainless Steel CD4MCu.

Maximum Operating Pressure 79 psi (545 kPa).*

Semi-Open Type, Two Vane Impeller: Stainless Steel CD4MCu.

Handles 3" (76.2 mm) Diameter Spherical Solids.

Impeller Shaft: Stainless Steel 17-4 PH.

Replaceable Wear Plate: Stainless Steel CD4MCu.

Removable Adjustable Cover Plate: Stainless Steel CD4MCu;
64 lbs. (29 kg).

Seal Plate: Stainless Steel CD4MCu.

Flap Valve: Fluorocarbon (DuPont Viton® or Equivalent) w/Stainless Steel Reinforcing.

Bearing Housing: Stainless Steel CD4MCu.

Radial Bearing: Open Single Row Ball.

Thrust Bearing: Open Double Row Ball.

Bearing and Seal Cavity Lubrication: SAE 30 Non-Detergent Oil.

Suction Flange: Stainless Steel CD4MCu.

Discharge Flange: Stainless Steel 316.

Gaskets: Fluorocarbon (DuPont Viton® or Equivalent), PTFE, Cork, and Rubber.

O-Rings: Fluorocarbon (DuPont Viton® or Equivalent).

Hardware: Stainless Steel 316.

Pressure Relief Valve: Stainless Steel 316.

Bearing and Seal Cavity Oil Level Sight Gauges.

Optional Equipment: Metal Bellows Seal. Automatic Air

Release Valve. 120V/240V Casing Heater. High Pump

Temperature Shutdown Kit. Self-Cleaning Wear Plate.

Stainless Steel CD4MCu Suction and Discharge Spool Flanges:

6" ASA (**Specify Model T6A65S-B /F**).

150 mm DIN 2527 (PN16) (**Specify Model T6A65S-B /FM**).

**Consult Factory for Applications Exceeding
Maximum Pressure and/or Temperature Indicated.*



Shown with Optional Suction & Discharge Spool Flanges (Available in ASA or DIN Standard Sizes).

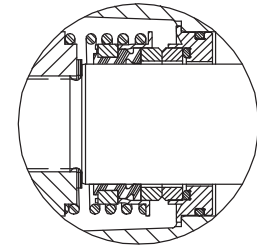
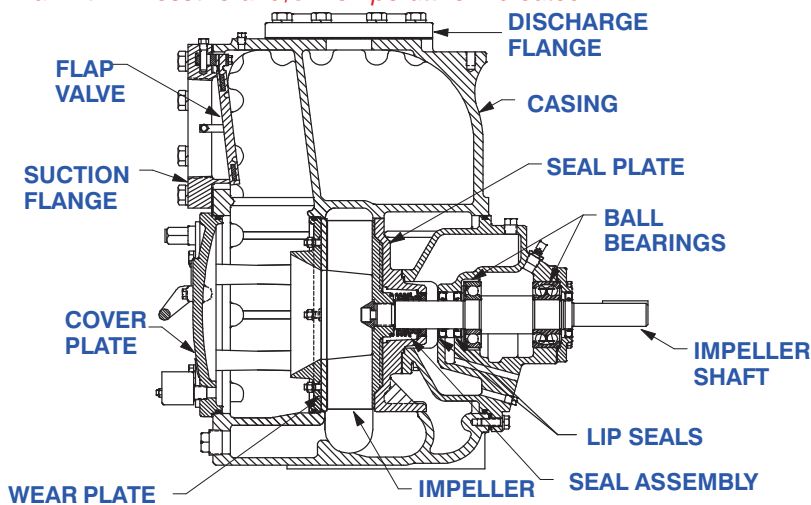

SEAL DETAIL

Mechanical, Oil-Lubricated, Double Floating, Self-Aligning. Silicon Carbide Rotating and Stationary Faces. Stainless Steel 316 Stationary Seat. Fluorocarbon Elastomers (DuPont Viton® or Equivalent). Stainless Steel 316 Cage and Spring. Maximum Temperature of Liquid Pumped, 160°F (71°C).*



THE GORMAN-RUPP COMPANY • MANSFIELD, OHIO

GORMAN-RUPP OF CANADA LIMITED • ST. THOMAS, ONTARIO, CANADA

www.grpumps.com

Specifications Subject to Change Without Notice

Printed in U.S.A.

Specification Data

SECTION 55, PAGE 2230

APPROXIMATE DIMENSIONS and WEIGHTS

NET WEIGHT: 875 LBS. (397 KG.)*
SHIPPING WEIGHT: 930 LBS. (422 KG.)*
EXPORT CRATE: 32.5 CU. FT. (0,92 CU. M.)
***ADD 30 LBS. (13,6 KG.) W/EACH SPOOL FLANGE**

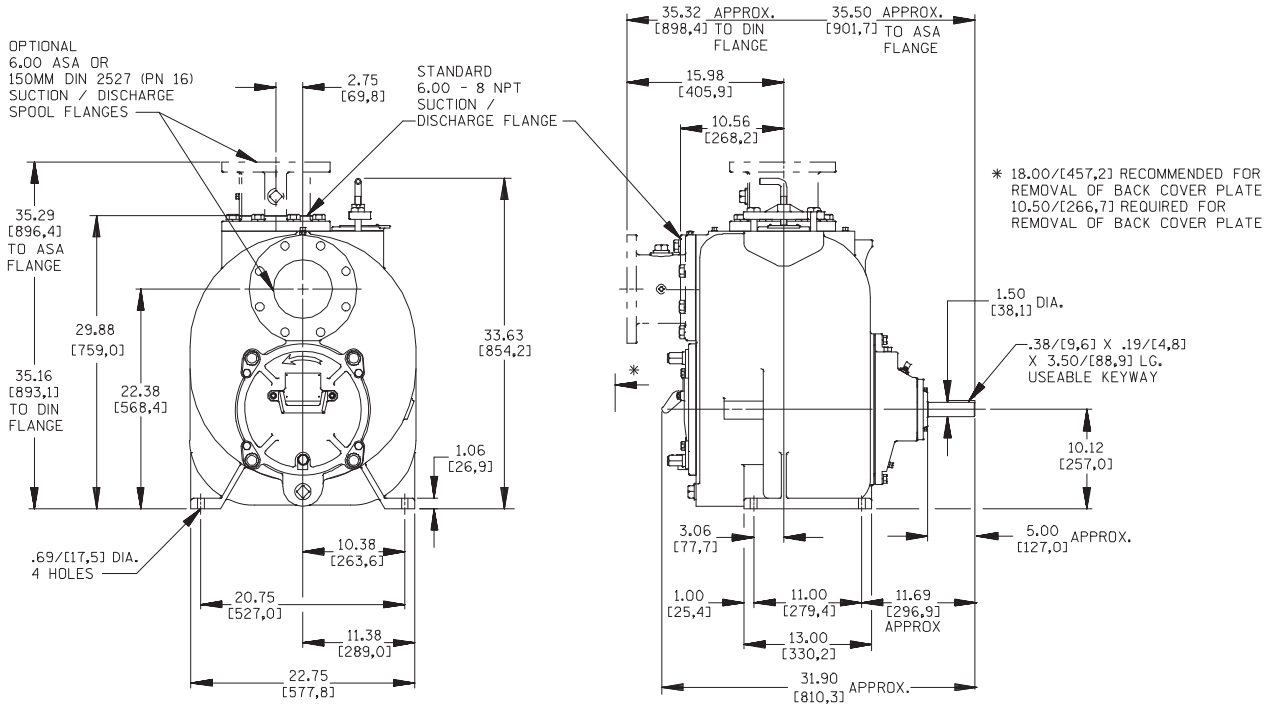

NOTE: OPTIONAL ASA OR DIN STANDARD SUCTION & DISCHARGE SPOOL FLANGES AVAILABLE

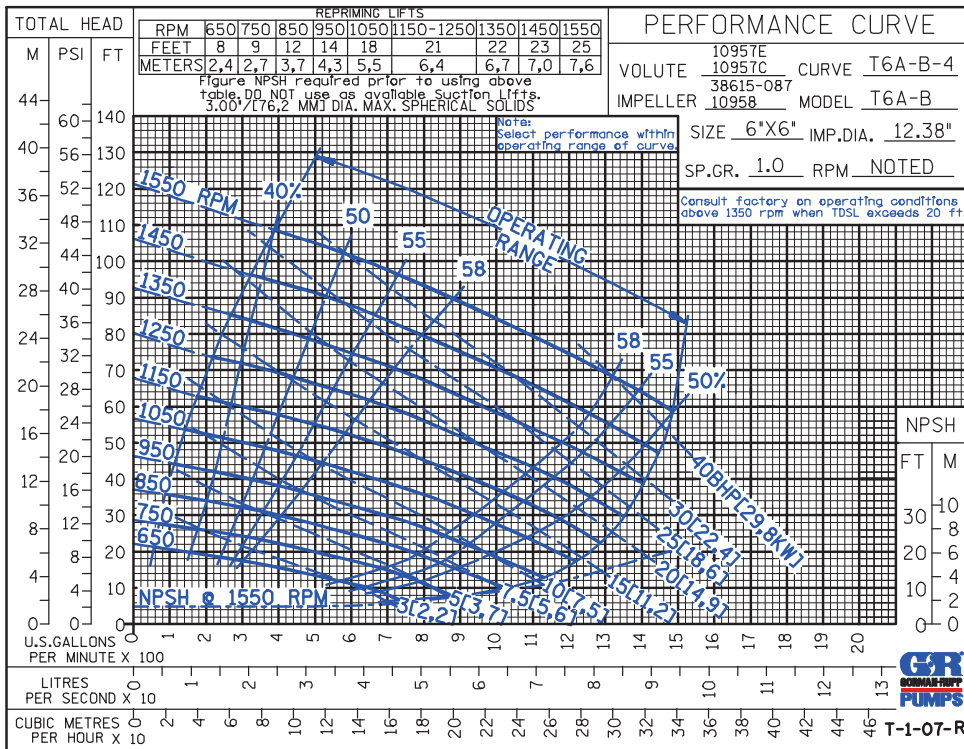

THE GORMAN-RUPP COMPANY • MANSFIELD, OHIO

GORMAN-RUPP OF CANADA LIMITED • ST. THOMAS, ONTARIO, CANADA

Specifications Subject to Change Without Notice

Printed in U.S.A.